

VANDALSTOP PRODUCTS™

TECHNICAL DATA SHEET

MODEL # OFUX2

FLIP FRONT DISPENSER

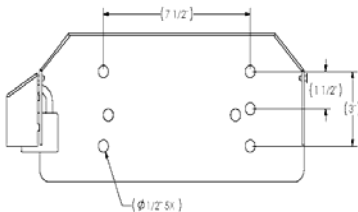
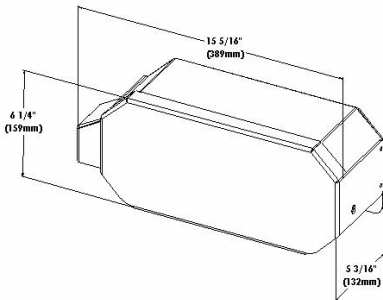

Version 2004-1
This document is subject to change without formal notice.

FLIP FRONT TOILET DISPENSER 2 ROLL

- VANDAL RESISTANT
- DRIP DEFLECTIVE
- SHROUDED PADLOCK HASP
- SURFACE MOUNTED
- MULTIPLE PAPER STYLES
- MEETS CRES* SPECIFICATIONS
- LIFETIME FUNCTIONAL WARRANTY

CONSTRUCTION:

HOUSING AND DOOR:

- Manufactured from 12-gauge 316L stainless steel.

FINISH

- Stainless steel satin # 4 finish.

MOUNTING

- Five 1/2-inch surface mounting hole placements.

CAPACITY:

- 2 standard-core 5 " or 2 high-density 5" rolls.

INSTALLATION:

Secure fixture to wall with appropriate 1/2" stainless steel anchoring hardware for optimal installation strength (not provided). Recommend 3/4" or greater back bracing for walls. Partitions may require T-nuts or other suitable anchoring devices. When possible it is recommended that units be through bolted back-to-back providing optimal installation strength.

GUIDE SPECIFICATION:

Dispenser shall be constructed with American-made 12 gauge 316L stainless steel assembled with TIG welds, polished smooth and edges de-burred. Dispenser shall not be cross-metal contaminated during manufacturing construction. Dispenser shall have housing covering tissue paper and have protective shroud for regular padlock use (padlock not furnished). Dispenser shall have 1/2 inch mounting holes. Dispenser shall accept multiple paper styles, be drip deflective and shall include a lifetime functional warranty.

Overall dimensions: 15^{-5/16} W x 6" H x 5^{-3/16} D

Surface Mount 2 Roll Dispenser shall be:

Vandal Stop Products™ Model: OFUX2

* CRES = Corrosion Resistance

Vandal Stop Products™
P.O. Box 55, Chico, CA 95927
Phone: 888-904-7867 FAX 530-343-5167
Web Site: <http://www.vandalstop.com>