

VANDALSTOP PRODUCTS™

TECHNICAL DATA SHEET

MODEL # SWR

SANITARY WASTE RECEPTALCE

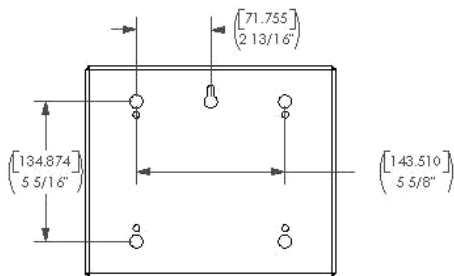
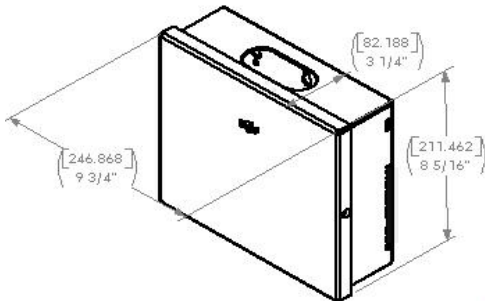

SANITARY WASTE RECEPTACLE

- VANDAL RESISTANT
- DRIP DEFLECTIVE
- CAM LOCK
- SURFACE MOUNTED
- MEETS CRES® SPECIFICATIONS
- LIFETIME FUNCTIONAL WARRANTY

CONSTRUCTION:

HOUSING AND HINDGED DOOR

- Manufactured from 12-gauge 316L stainless steel

FINISH

Stainless steel satin # 4 finish.

MOUNTING

- Five-1/2 inch and four-1/4 inch surface mounting hole placements.

INSTALLATION:

Secure fixture to wall with appropriate 1/2 inch stainless steel anchoring hardware for optimal installation strength (not provided). Recommend 3/4 inch or greater back bracing for walls. Partitions may require T-nuts or other suitable anchoring devices. When possible it is recommended that units be through bolted back-to-back providing optimal installation strength.

GUIDE SPECIFICATION:

Receptacle shall be constructed with American-made 12 gauge 316L stainless steel assembled with TIG welds, polished smooth and edges de-burred. Receptacle shall not be cross-metal contaminated during manufacturing construction. Receptacle shall be covered and designed for common padlock use. Receptacle shall have 1/2 inch mounting holes, be drip deflective and shall include a lifetime functional warranty.

Overall dimensions: 9-^{3/4} W x 8-^{5/16} H x 3-^{1/4} D

Surface Mount Sanitary Waste Receptacle shall be:

Vandal Stop Products™ Model: SWR

*CRES=Corrosion Resistance

Version 2004-1

This document is subject to change without formal notice.

Vandal Stop Products™

P.O. Box 55, Chico, CA 95927

Phone: 888-904-7867 FAX 530-343-5167

Web Site: <http://www.vandalstop.com>