

VANDAL STOP PRODUCTS™

TECHNICAL DATA SHEET

MODEL # TR-001

WASTE RECEPTACLE

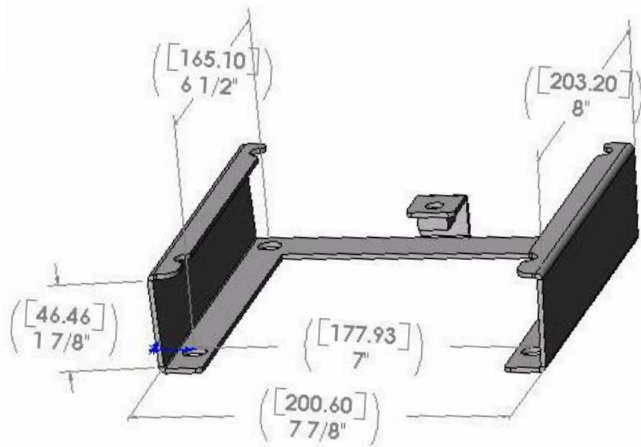
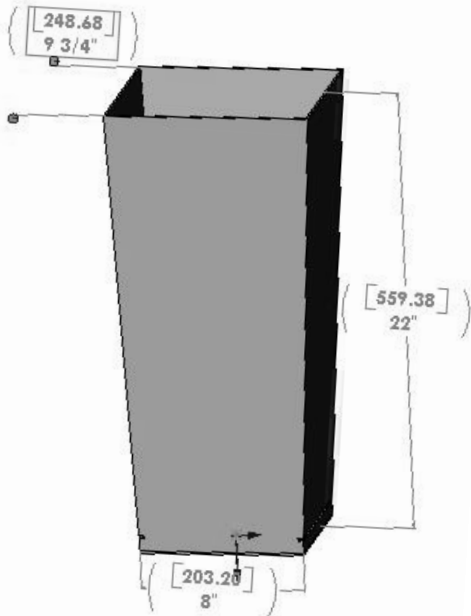

Version 2004-1
This document is subject to change without formal notice.

VANDAL RESISTANT WASTE RECEPTACLE

- ANCHORABLE
- EASILY CLEANED
- TAPERED DESIGNED FOR EASE OF BAG REMOVAL
- SURFACE MOUNTED
- MEETS CRES* SPECIFICATIONS
- LIFETIME FUNCTIONAL HOUSING WARRANTY

CONSTRUCTION:

HOUSING

- Manufactured from 12-gauge 316L stainless steel.

FINISH

- Stainless steel satin # 4 finish.

MOUNTING

- Four 1/2" surface mounting hole placements.

CAPACITY

- 12 Gallon

INSTALLATION:

Secure fixture to floor with appropriate 1/2" stainless steel anchoring hardware for optimal installation strength (not provided).

GUIDE SPECIFICATION:

Waste Receptacle shall be constructed with American-made 12 gauge 316L stainless steel assembled with TIG welds, polished smooth and edges de-burred. Waste Receptacle shall not be cross-metal contaminated during manufacturing construction. Waste Receptacle shall have 1/2 inch mounting holes and include a lifetime functional housing warranty.

Overall dimensions: 9 3/4" W X 22" H X 8" D

Approximate Weight: 24lbs.

Waste Receptacle shall be:

Vandal Stop Products™ Model: TR-001

Optional Waste Receptacle Anchoring Bracket shall be:

Vandal Stop Products™ Model : TR-002

*CRES = Corrosion Resistance

Vandal Stop Products™
P.O. Box 55, Chico, CA 95927
Phone: 888-904-7867 FAX 530-343-5167
Web Site: <http://www.vandalstop.com>