

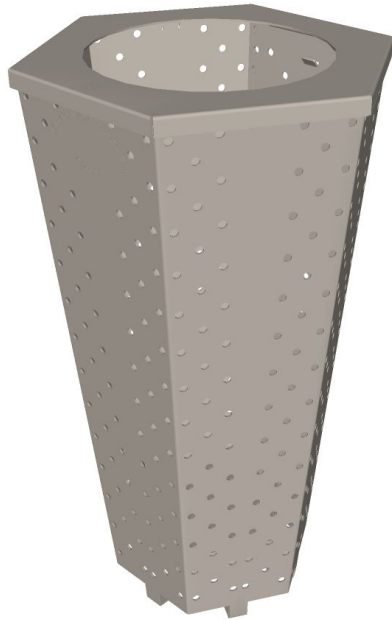

VSP-TR-16: Waste Receptacle - Specs sheet



Features:

- Vandal Resistant
- Made in USA
- Base Mount Anchored
- Top Lid Opening (Lockable)
- Padlock Security Shroud (Optional)
- Attractive and Sturdy Hexagonal Form Factor
- Easily Brush, Spray or Hose Cleaning
- Internal Bag Hanging Tabs
- Non-Floodable
- Tapered Design To Ease Bag Removal
- Corrosion Resistant
- Industry Leading Warranty against Vandalism

Specifications:

- Width: 17-1/8"
- Height: 29"
- Depth: 14-7/8"
- Weight: 29lbs

Material Options:

- 12-gauge 304L Stainless Steel
- 12-gauge 316L Stainless Steel

Finish:

- #4 Brushed Satin Finish

Mounting:

- Six 1/2" Surface Mounting Hole Placements

Capacity:

- 15.5 US Gallons

Options:

- Padlock Shroud

Installation: Secure fixture to floor with appropriate 1/2" stainless steel anchoring hardware (not provided) for optimal installation strength.

Guide Specification: Receptacle shall be constructed with American made, 12 gauge 304L or 12 gauge 316L Stainless Steel joined /w TIG welds and edges de-burred. Receptacle shall not be cross-metal contaminated during manufacturing construction. Protective shroud adds security for padlock. Receptacle shall have 1/2" mounting holes. 316L SS shall be used for US Navy maritime use or if exposure to salt water is prevalent.

Warranty: See Website Product Page for Details.

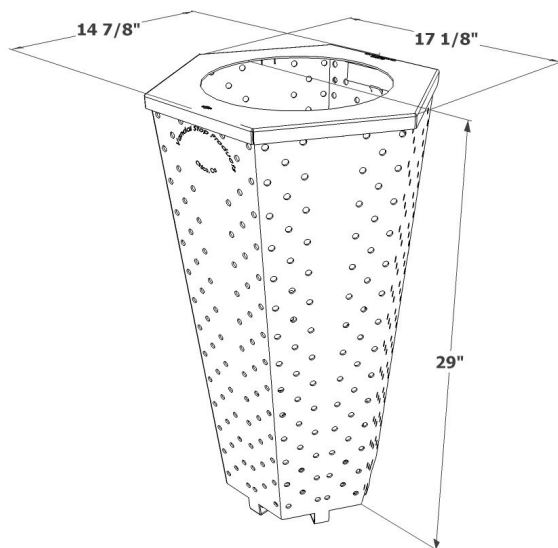
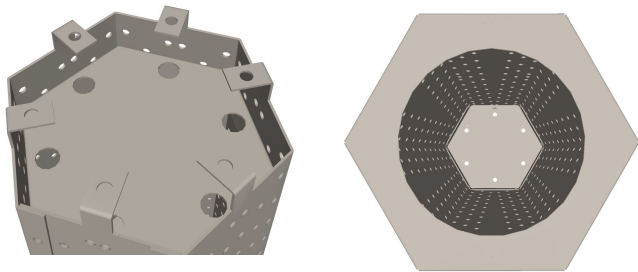

Phone
(530) 894 7867

www.vandalstop.com

Vandal Stop Products by Atlas American LLC
1930 Village Center Circle #3-5871
Las Vegas, NV 89134

E-Mail
sales@vandalstop.com